

# VEX-P

## Combination of Drilling and Front and Back Chamfering in One Operation.

- High performance replaceable carbide drill tip combined with patented SNAP chamfering system
- VEX drill geometry for better chip control
- Quick and easy drill tip and chamfer blade replacement
- Coolant Through
- Sizes 11.0-17.0mm (.433-.669") available from stock

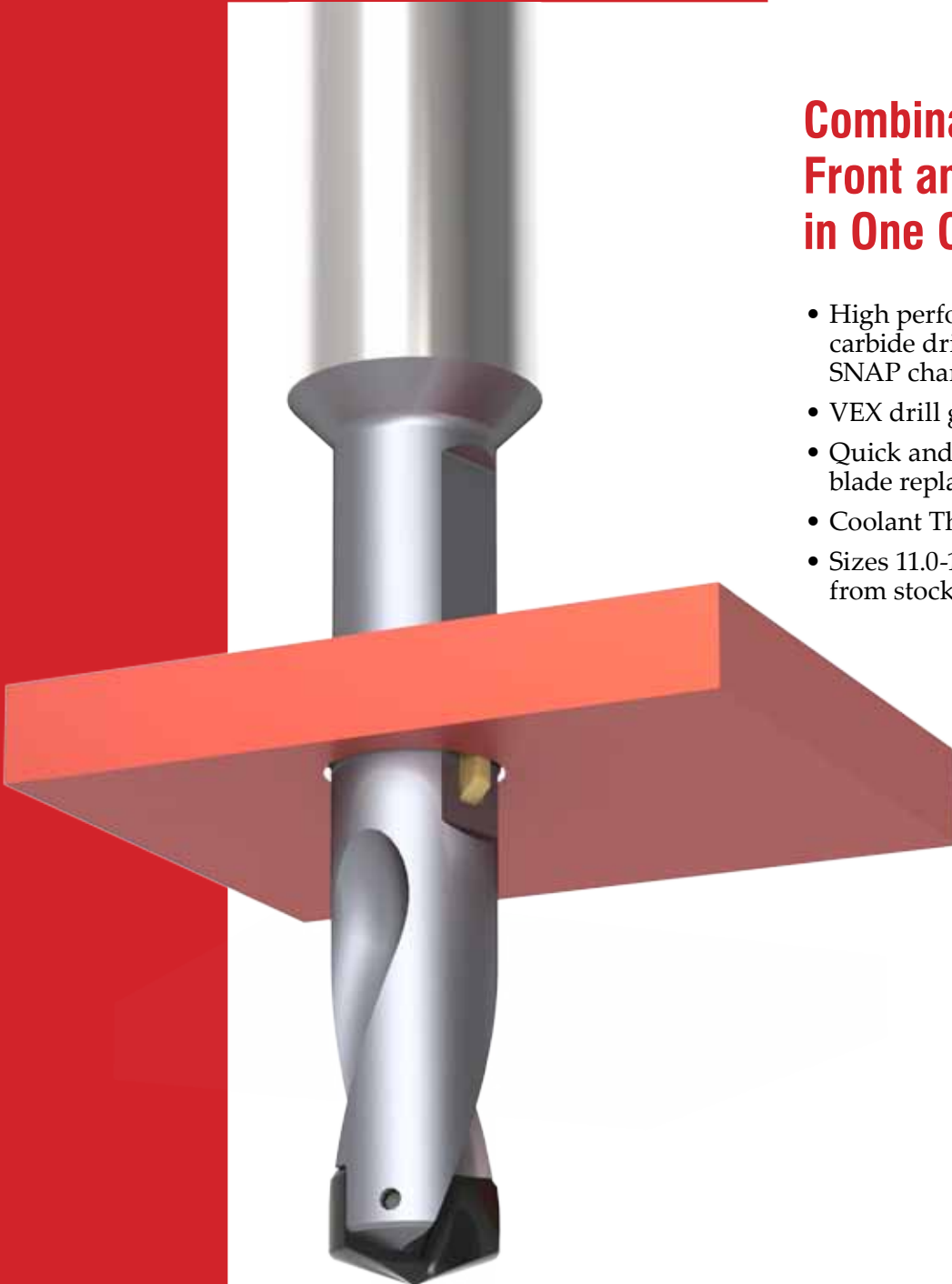

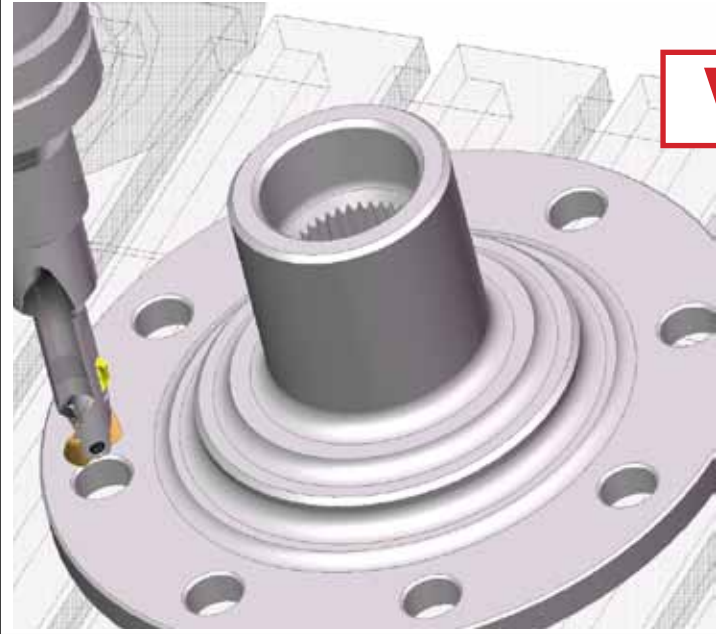

## VEX-P

**Combination of Drilling and Front/Back Chamfering in One Operation.**

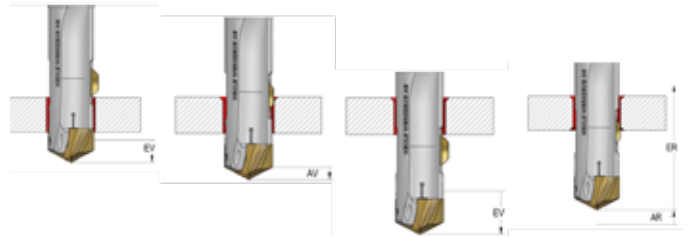

### Study Details



**TOOL**  
VEX-P

**PRODUCTION**  
30,000 parts per month

**MACHINE**  
Vertical CNC

**MATERIAL**  
1050 Steel

**HOLE SIZE**  
Ø13.0mm (.512") drilled front and back chamfered in one single operation

**DETAILS**  
Tool:  
Speed: VEX-P SNAP12 drill combi  
Feed: 3720 RPM 500 SFM  
VEX: 0.25 mm/rev (.0101" IPR)  
Life: SNAP: 0.20 mm/rev (.008" IPR)  
VEX: 4,500 holes/  
SNAP: 13,500 holes

**REPLACING**  
Solid carbide and secondary operation

The VEX-P tool combines a replaceable solid carbide high performance drill tip with HEULE's patented SNAP chamfering system to enable drilling and front and back chamfering in one operation.

*"The Vex-P combination tool replaced two tools and cut our cycle time in half for that operation..."*

For bores from diameters 11.00 mm to 17.0 mm (0.433 - 0.669") and bore depths up to 1.5 times diameter.



## How to Select a VEX-P Tool

1. Determine the drill hole size.
2. Select the appropriate drill tip and the coordinating tool holder.
3. Choose the SNAP chamfer blade according to the needed chamfer size.

### 1 Series

Bore Range	Series
11.0-13.99	C
14.0-17.0	D

### 2 Bore Diameter Ød

Indicate the bore diameter here. For example: Ø15.10 = 1510  
 Standard size as shown.

### 3 Cutting Material

Carbide K20-K30	1
-----------------	---

### 4 Coating

TiAlN	A
DLC	D

Within the holder range, drill tips of different diameters can be exchanged within the same series number.

## Tool Description

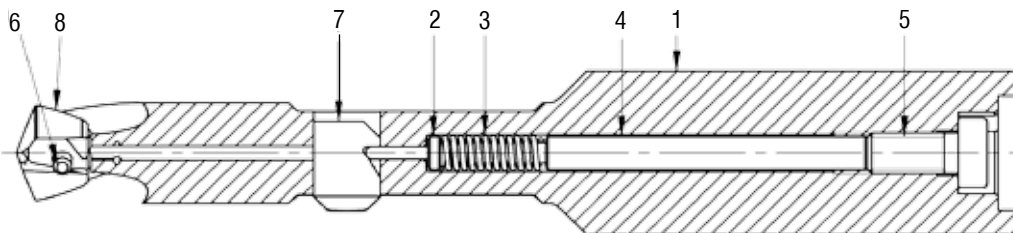

- 1 Tool Body
- 2 Control Bolt
- 3 Spring
- 4 Distance Pin
- 5 Cap Screw
- 6 Torx Screw
- 7 Chamfer Blade
- 8 Drill Tip

Order Number Example: P- P- D 1450 -1 A

- 1 = Series
- 2 = Bore-Ød
- 3 = Cutting Material
- 4 = Coating

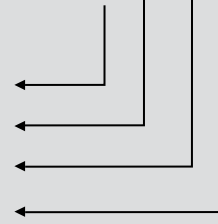

Order Example:

Bore-Ød	= 14.50mm
Carbide Quality	= K20-K30
Coating	= TiAlN
Order Number: P-P-D-1450-1A	



## Spare Parts

Bore Range	Series	2 Control Bolt	3 Spring	4 Distance Pin	5 Cap Screw GH-H-S-	Hex Wrench GH-H-S-	Hex Wrench Description mm
11.0 - 11.99	C	GH-Q-E-0078	GH-H-F-0027	GH-Q-E-0503	0538-1	2100	2.5
12.0 - 13.99	C	GH-Q-E-0002	GH-H-F-0012	GH-Q-E-0514	0524-1	2103	3.0
14.0 - 15.49	D	GH-Q-E-0002	GH-H-F-0012	GH-Q-E-0514	0524-1	2103	3.0
15.5 - 17.0	D	GH-Q-E-0002	GH-H-F-0012	GH-Q-E-0515	0524-1	2103	3.0

Bore Range	Series	6 Torx Screw	Clamp Screw Description	Torx Wrench GH-H-S-	Torque Setting Nm	<i>Recommended</i> Precision Torque Wrench Wrench Order # Description	
11.0 - 11.99	C	GH-H-S-0038	M2.2 x 10.2 T7	2001	1.1	HT-TX-H-0002	Handle 1.1 NM with IP7 Torx Bit
12.0 - 13.99	C	GH-H-S-0038	M2.2 x 10.2 T7	2001	1.1		
14.0 - 15.49	D	GH-H-S-0035	M2.5 x 12 T8	2002	1.2	HT-TX-H-0003	Handle 1.2 NM with T8 Torx Bit
15.5 - 17.0	D	GH-H-S-0035	M2.5 x 12 T8	2002	1.2		

# VEX-P 1.5xd

## Drill/Chamfer Tools – Series C

For holes 11.0 - 13.9mm .433 - .547"

HTC019

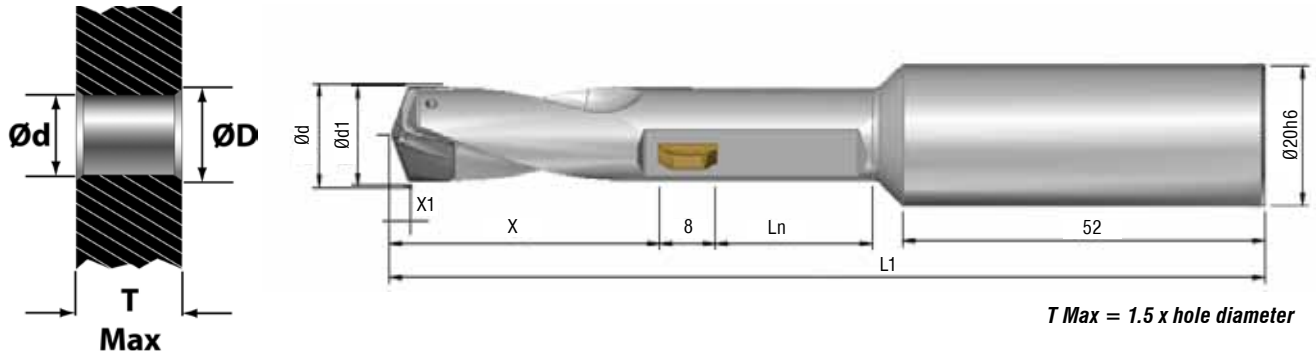

T Max = 1.5 x hole diameter

### VEX-P Series C Tool Holders Ødx1.5 with Coolant Through

Tool Holder Order Number	Ød Range	Ød1	L1	Ln	X1	X
GH-Q-O-4250E	11.0 – 11.4	10.8 (.425")	116.9 (4.602")	17.2 (.677")	2.5 (.099")	33.5 (1.319")
GH-Q-O-4251E	11.5 – 11.9	11.3 (.445")	118.2 (4.654")	18.0 (.709")	2.6 (.102")	34.3 (1.350")
GH-Q-O-4252E	12.0 – 12.4	11.8 (.465")	119.4 (4.701")	18.7 (.736")	2.7 (.106")	35.1 (1.382")
GH-Q-O-4253E	12.5 – 12.9	12.3 (.484")	120.7 (4.752")	19.5 (.768")	2.8 (.110")	35.8 (1.409")
GH-Q-O-4254E	13.0 – 13.4	12.8 (.504")	121.9 (4.799")	20.2 (.795")	2.9 (.114")	36.6 (1.441")
GH-Q-O-4255E	13.5 – 13.9	13.3 (.524")	123.2 (4.850")	21.0 (.827")	3.0 (.118")	37.3 (1.469")

### VEX-P Series C Drills & Chamfer Blades

Ød Drill*	Tool Holder Order Number	Carbide TiAlN Drill Order #	Cmf. Series	Chamfer Blade Order Number (fab)*			
				(0.25mm x 45°) GH-Q-M-	(0.5mm x 45°) GH-Q-M-	(0.75mm x 45°) GH-Q-M-	(1.0mm x 45°) GH-Q-M-
11.0mm (.433")	GH-Q-O-4250E	P-P-C-1100-1A	8	-03726 (11.5)	-03727 (12.0)	-03728 (12.5)	-
11.1mm (.437")	GH-Q-O-4250E	P-P-C-1110-1A		-03727 (12.0)	-03728 (12.5)	-03729 (13.0)	-
11.5mm (.453")	GH-Q-O-4251E	P-P-C-1150-1A		-03727 (12.0)	-03728 (12.5)	-03729 (13.0)	-
11.9mm (.469")	GH-Q-O-4251E	P-P-C-1190-1A		-03728 (12.5)	-03729 (13.0)	-03730 (13.5)	-
12.0mm (.472")	GH-Q-O-4252E	P-P-C-1200-1A	12	-03740 (12.5)	-03741 (13.0)	-03742 (13.5)	-03743 (14.0)
12.5mm (.492")	GH-Q-O-4253E	P-P-C-1250-1A		-03741 (13.0)	-03742 (13.5)	-03743 (14.0)	-03744 (14.5)
12.7mm (.500")	GH-Q-O-4253E	P-P-C-1270-1A		-03741 (13.0)	-03742 (13.5)	-03743 (14.0)	-03744 (14.5)
13.0mm (.511")	GH-Q-O-4254E	P-P-C-1300-1A		-03742 (13.5)	-03743 (14.0)	-03744 (14.5)	-03745 (15.0)
13.5mm (.531")	GH-Q-O-4255E	P-P-C-1350-1A		-03743 (14.0)	-03744 (14.5)	-03745 (15.0)	-03746 (15.5)

\*Special sizes and geometries available on request

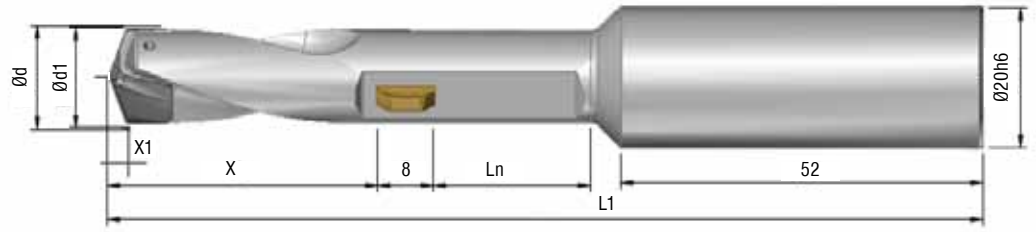
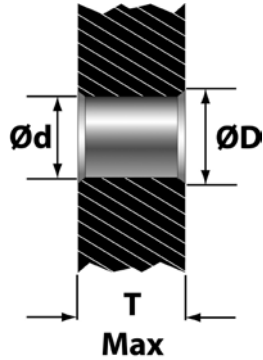

T Max = 1.5 x hole diameter

### VEX-P Series D Tool Holders Ødx1.5 with Coolant Through

Tool Holder Order Number	Ød Range	Ød1	L1	Ln	X1	X
GH-Q-0-4256E	14.0 – 14.4	13.8 (.543")	123.4 (4.858")	21.7 (.854")	3.1 (.122")	37.1 (1.461)
GH-Q-0-4257E	14.5 – 14.9	14.3 (.563")	124.7 (4.909")	22.5 (.886")	3.2 (.126")	37.8 (1.488)
GH-Q-0-4258E	15.0 – 15.4	14.8 (.583")	125.9 (4.957")	23.2 (.913")	3.3 (.130")	38.6 (1.520)
GH-Q-0-4259E	15.5 – 15.9	15.3 (.602")	127.2 (5.008")	24.0 (.945")	3.4 (.134")	39.3 (1.547)
GH-Q-0-4260E	16.0 – 16.4	15.8 (.622")	128.4 (5.055")	24.7 (.972")	3.5 (.138")	40.1 (1.579)
GH-Q-0-4261E	16.5 – 17.0	16.3 (.642")	129.7 (5.106")	25.5 (1.004")	3.6 (.142")	40.8 (1.606)

### VEX-P Series D Drills & Chamfer Blades

Ød Drill*	Tool Holder Order Number	Carbide TiAlN Drill Order #	Cmf. Series	Chamfer Blade Order Number (fab)*			
				(0.25mm x 45°) GH-Q-M-	(0.5mm x 45°) GH-Q-M-	(0.75mm x 45°) GH-Q-M-	(1.0mm x 45°) GH-Q-M-
14.0mm (.551")	GH-Q-0-4256E	P-P-D-1400-1A	12	-03744 14.5	-03745 15.0	-03746 15.5	-03747 16.0
14.3mm (.562")	GH-Q-0-4256E	P-P-D-1430-1A		-03744 14.5	-03745 15.0	-03746 15.5	-03747 16.0
14.5mm (.571")	GH-Q-0-4257E	P-P-D-1450-1A		-03745 15.0	-03746 15.5	-03747 16.0	-03748 16.5
15.0mm (.591")	GH-Q-0-4258E	P-P-D-1500-1A		-03746 15.5	-03747 16.0	-03748 16.5	-03749 17.0
15.5mm (.610")	GH-Q-0-4259E	P-P-D-1550-1A		-03747 16.0	-03748 16.5	-03749 17.0	-03750 17.5
15.9mm (5/8")	GH-Q-0-4259E	P-P-D-1590-1A		-03748 16.5	-03749 17.0	-03750 17.5	-03751 18.0
16.0mm (.630")	GH-Q-0-4260E	P-P-D-1600-1A		-03748 16.5	-03749 17.0	-03750 17.5	-03751 18.0
16.5mm (.650")	GH-Q-0-4261E	P-P-D-1650-1A		-03749 17.0	-03750 17.5	-03751 18.0	-03752 18.5
17.0mm (.669")	GH-Q-0-4261E	P-P-D-1700-1A		-03750 17.5	-03751 18.0	-03752 18.5	-03753 19.0

\*Special sizes available on request

### VEX-P Speeds and Feeds

**IMPORTANT:** Cutting data is for guidance only and based on recommended values, assuming ideal conditions. Cutting data may need to be adjusted subject to the application settings, machining or consistency of the workpiece.

Material	Hardness HB	SFM	IPR Ø11-13.9	IPR Ø14-16.9
<b>Alloy Steel</b>	280-415	130-300	.005-.009	.007-.012
<b>Med Carbon Steel</b>	300-450	300-425	.006-.012	.008-.014
<b>Free machining steel</b>	425-550	220-450	.006-.012	.007-.013
<b>Low-Carbon steel</b>	350-520	250-490	.007-.012	.008-.014
<b>Cast steel</b>		150-250	.004-.008	.006-.012
<b>High-alloy steel</b>	100-130	100-220	.005-.010	.006-.012
<b>Tool steel</b>	205-265	120-210	.005-.008	.007-.010
<b>Hardened steel</b>	120-155	65-130	.004-.006	.005-.008
<b>Chilled castings*</b>	80-145	65-145	.004-.006	.005-.008
<b>Stainless steel*</b>	100-240	80-210	.004-.008	.005-.008
<b>Titanium*</b>	100-140	90-130	.004-.006	.005-.008
<b>Grey cast iron</b>	335-500	300-590	.010-.014	.013-.020
<b>Nodular cast iron</b>	335-500	335-525	.008-.013	.011-.019
<b>Aluminium**</b>	1000-1400	400-1000	.010-.016	.011-.016
<b>Aluminum-casting alloys**</b>	75-1000	300-800	.010-.015	.013-.018
<b>Brass</b>	660	300-500	.010-.014	.015-.016
<b>Copper alloys</b>	425	300-460	.004-.010	.006-.012
<b>Bronze-Short Chipping</b>	295-360	295-360	.012-.014	.015-.016
<b>Bronze-Long Chipping</b>		130-200	.006-.012	.006-.015

Note: Carbide - TiAlN/TiN (drill and chamfer) recommendation

\*Optional geometry available on request, contact HEULE.

\*\*Recommend DLC coating

## VEX-P Programming Sequence

It is not necessary to change the direction of rotation or stop the spindle

**WF:** Working feed

**RF:** Rapid feed

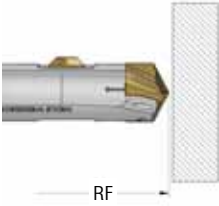
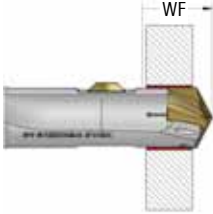
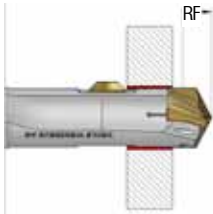
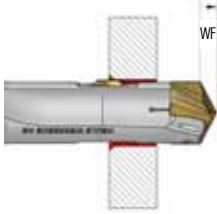
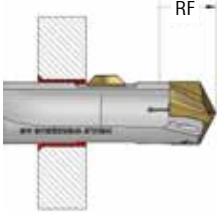
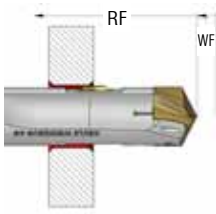
	<p><b>Step 1:</b> Rapid feed of the tool to within clearance for the work piece</p>
	<p><b>Step 2:</b> With forward working feed, feed the tool through the workpiece until the hole is drilled and the drill tip is clear of the bore.</p>
	<p><b>Step 3:</b> Rapid feed the tool so the SNAP blade is within clearance of the workpiece top surface or burr.</p> <p>Note: Clearance distance (+1.0mm/0.04")</p>
	<p><b>Step 4:</b> With working feed, cut the top chamfer. Continue feeding until the SNAP blade is completely retracted into the tool body.</p>
	<p><b>Step 5:</b> Use rapid feed to position the SNAP blade on the far side of the part. Position the tool so the SNAP blade is completely extended and clear of the part or burr.</p>
	<p><b>Step 6:</b> With back working feed, cut the back chamfer. When the SNAP blade is completely within the tool and clear of the back surface, the tool can be extracted with rapid feed.</p>

### How to Replace the Snap Chamfer Blade

**Step 1:**

Turn cap screw counterclockwise approximately 3-5 turns.

**Step 2:**

Remove the blade by simply pushing it past center and out the back of the tool.

**Step 3:**

Install the new blade by pushing the back side of the blade through the window until it “snaps”. Retighten screw clockwise. Check to make sure blade moves freely.

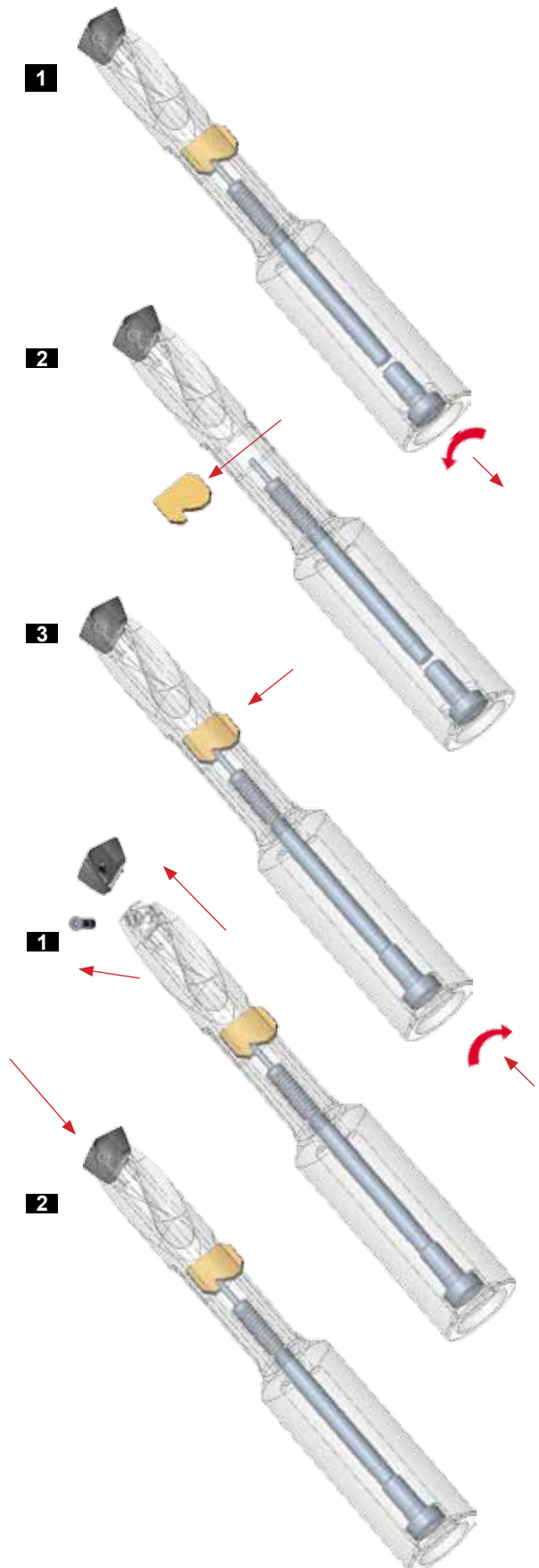

### How to Replace the Drill Tip

**Step 1:**

Use Torx wrench to remove drill tip. Clean the drill connection.

**Step 2:**

Insert new drill tip and screw into holder. Tighten screw to recommended torque setting.